

## Introduction:

“Firesafe” offers a complete Science and Technology K-6 program for teachers. This program is derived from the Board of Studies (BOS) Syllabus. Headings for topics are basically the same as appear in the BOS document . Teacher learning programs can be developed from this program.

The central theme for this program is fire safety and awareness. The motive for this theme is to reduce the number of preventable fires that occur in our society and to reduce the number of injuries, deaths and damage that result from fires. Firesafe aims to complement the NSWRFSS Fireguard for Kids Program which is already operating in many schools.

### **Teachers please note:**

The activities in this workbook can be photocopied without permission provided that the NSW Rural Fire Service is acknowledged as the source.

Firesafe 1,2 & 3 are **FREE** publications of the NSW Rural Fire Service and are available in class sets.

### **Other resources**

- K-6  
Firesafe 1,2 & 3
- 7-12  
Fire Science 1,2 & 3
- A comprehensive list of **FREE** resources is available on the NSWRFSS web site: **[www.rfs.nsw.gov.au](http://www.rfs.nsw.gov.au)**

For more information and enquiries call freecall 1800 654 443

# CONTENTS

A place in time .....	5
What is the weather like? .....	7
Have a look at the wind .....	9
Back to nature.....	11
Feeling the fabric .....	13
Campfire safety .....	14
Getting about.....	15
Fire tanker.....	18
Helicopter .....	19
Car safety .....	20
Growing up and what is alive?.....	21
Plants in the bush .....	24
Bush fire safety .....	26
Hot and cold.....	27
How to cool a burn.....	30
Signs .....	31
Hot and cold taps .....	33
Good fires and bad fires.....	34
If you are caught in a bush fire .....	38
Stop drop and cover up .....	39
Stop drop, cover and roll .....	40
Matches and safety.....	43
Let's boil the billy .....	46
Burning candle .....	49
What would you do if? .....	50
Kids care .....	51
Let's communicate.....	53
Signs .....	56
Smoke alarm .....	57
Reporting a fire.....	58
Look around you .....	59
Home escape plan.....	62
Get down low and go, go, go .....	63
Help Smokey escape .....	64
Two ways out.....	66
Picture it.....	67
Toy world.....	69
Cardboard puppet rural fire fighter .....	71
What's for lunch?.....	73

# A PLACE IN TIME

# A PLACE IN TIME

OUTCOMES	TEACHING STRATEGY	RESOURCES
<p>Develop an understanding of changes that occur in weather.</p>	<ol style="list-style-type: none"> <li>1) Compile a word bank that describes weather patterns.</li> <li>2) Collect a variety of weather pictures eg. sun, wind, clouds, rain, snow.</li> <li>3) Associate weather patterns with various times of the year.</li> <li>4) Describe weather patterns prevalent during times of bush fire.</li> <li>5) Recognise the different types of weather that can occur at the same time in different parts of the country and different parts of the world.</li> </ol>	
<p>Undertake simple measurements to detect weather patterns.</p>	<ol style="list-style-type: none"> <li>1) Practise measuring temperature.</li> <li>2) Practise measuring rainfall.</li> </ol>	
<p>Relate the activity of people and animals to weather patterns.</p>	<ol style="list-style-type: none"> <li>1) Collect pictures of different activities of people during different weather eg. going to the beach during hot periods, sitting in front of the fire when it is cold.</li> <li>2) Select appropriate clothing to be used in different weather patterns.</li> <li>3) Recognise seasonal patterns of behaviour in animals and plants eg. birds nesting and plants flowering.</li> </ol>	

# WHAT IS THE WEATHER LIKE ?

Match each of the weather types with a word from the word bank.

rain    hot    dry    windy    cloudy

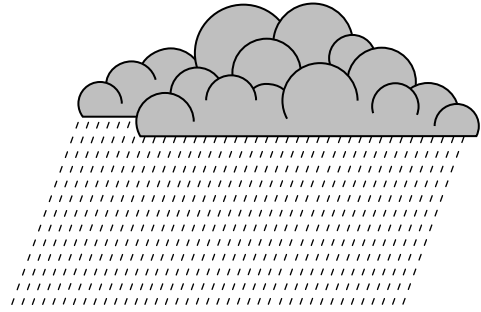
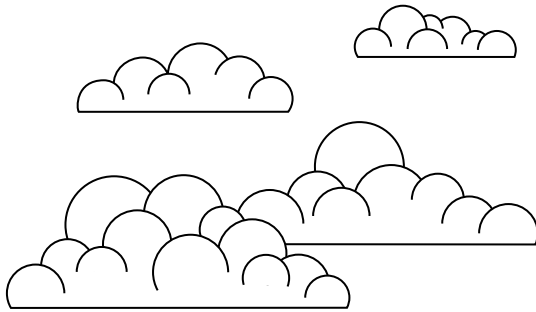
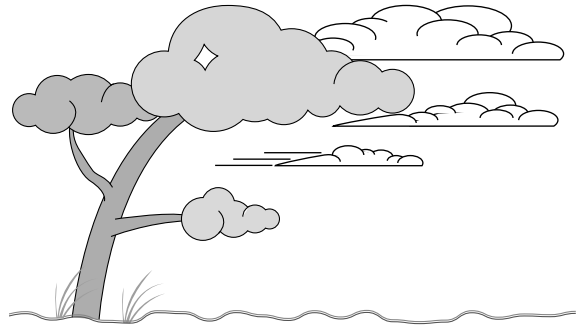
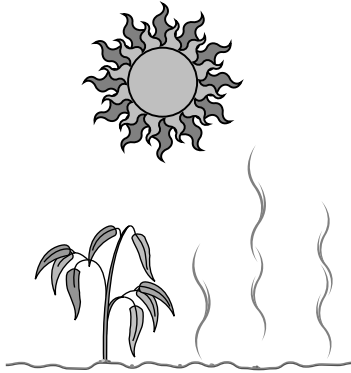

**CIRCLE THE TYPE OF WEATHER THAT CAUSES BUSH FIRES**

# WEATHER WORDS

F	R	O	S	T	C	L	O	U	D
N	I	A	R	W	W	C	Y	G	U
L	I	A	H	O	I	O	R	O	S
S	U	N	V	N	N	L	D	F	T
T	O	H	U	S	D	D	W	E	T

CLOUD

COLD

DRY

DUST

FOG

FROST

HAIL

HOT

RAIN

SNOW

SUN

WET

WIND

# HAVE A LOOK AT THE WIND

1. Talk about some things that we see that tell us about wind.
2. Collect some pictures that show us something about wind.
3. Make this wind spiral.

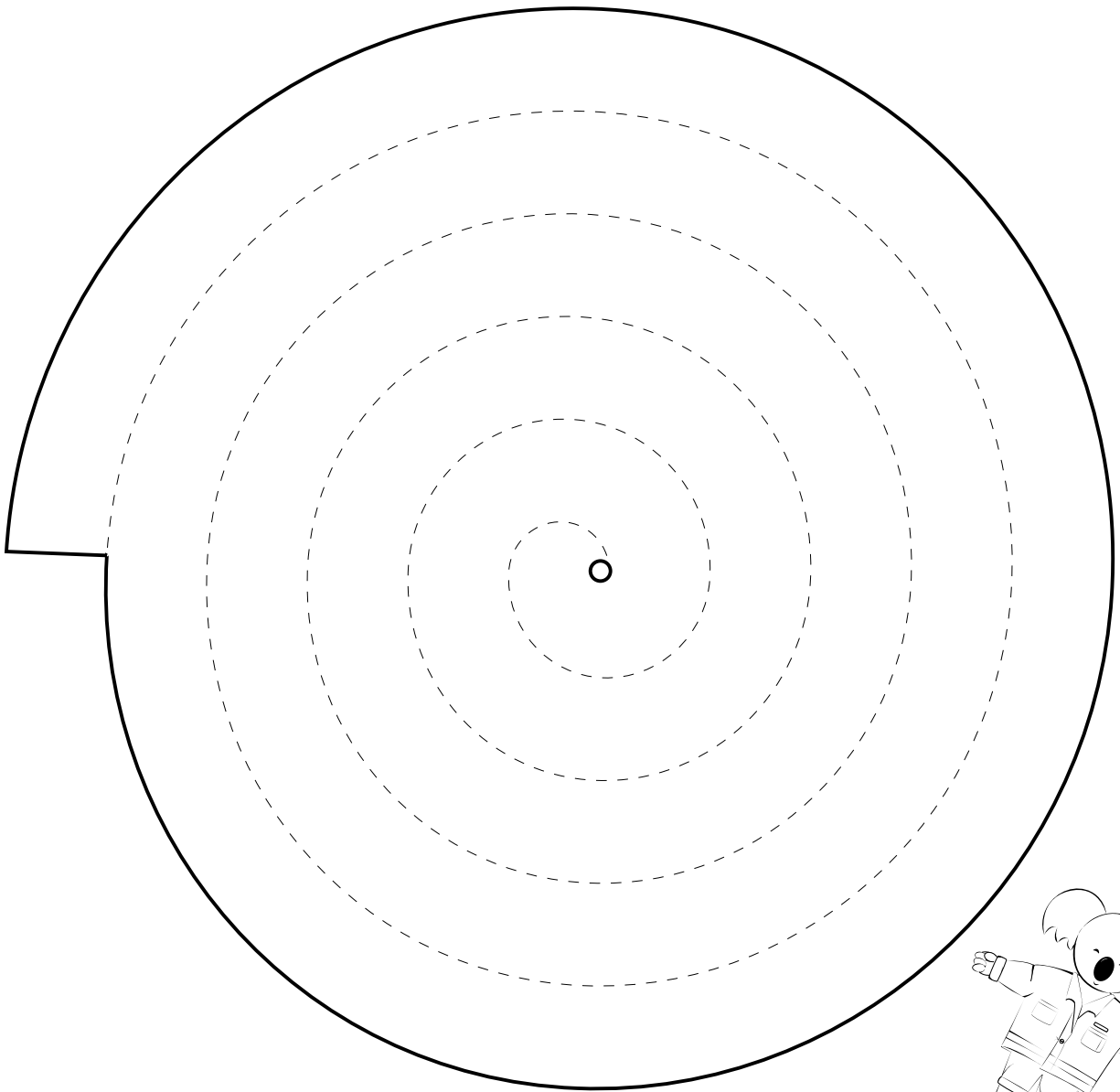

4. Carefully hold the wind spiral above a burning candle.

This shows us that fires create their own wind.

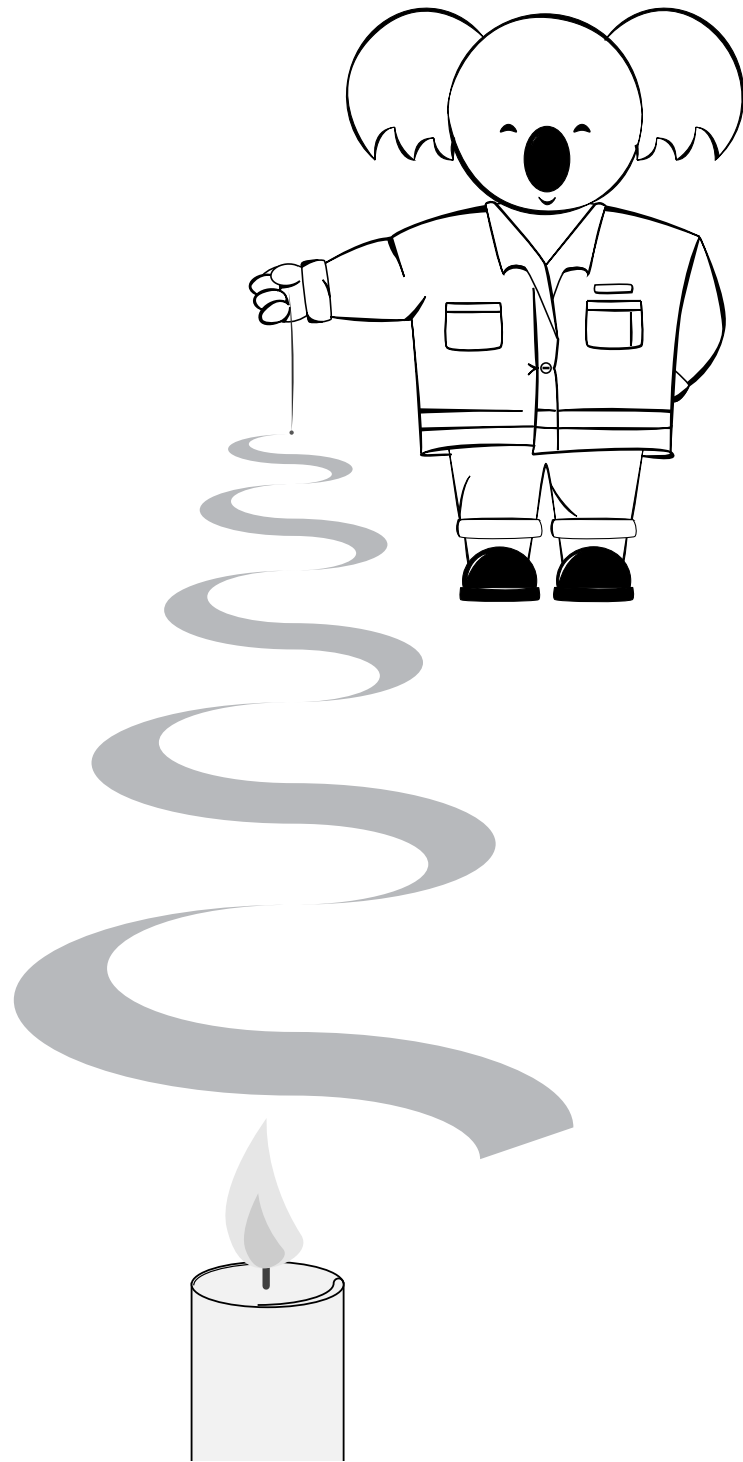

Hot air rises and makes the spiral .....

Fire makes its own .....

Wind makes the fire burn .....

wind   spin   faster
----------------------



# BACK TO NATURE

# BACK TO NATURE

OUTCOMES	TEACHING STRATEGY	RESOURCES
<p>Recognise how we use a variety of naturally occurring substances.</p>	<ol style="list-style-type: none"> <li>1) Collect a variety of naturally occurring substances.</li> <li>2) Differentiate between synthetic and naturally occurring substances.</li> <li>3) Categorise naturally occurring substances as fuels, clothing, building materials etc.</li> <li>4) Recognise that some things burn better than others and so make them good fuels or potential fire hazards.</li> <li>5) Observe the correct method to build a campfire.</li> <li>6) Collect some interesting natural architecture.</li> <li>7) Make a musical instrument from a naturally occurring substance.</li> <li>8) Categorise objects in the classroom as being natural or man made.</li> </ol>	
<p>Investigate the origin of our clothing.</p>	<ol style="list-style-type: none"> <li>1) Examine a variety of clothing labels to see what the garments are made of.</li> <li>2) Trace the origin of the fibre used in the fabric.</li> <li>3) Construct a "texture box" and recognise fabrics by feel.</li> <li>4) Talk about the flammability of different fabrics.</li> </ol>	
<p>Investigate the variety of building products used in home construction.</p>	<ol style="list-style-type: none"> <li>1) Make a simple survey of the types of materials what are used in a building's construction.</li> <li>2) Discuss the advantages and disadvantages of various building materials.</li> </ol>	

# FEELING THE FABRIC

1. Place a number of different fabric types onto a table.
2. Explain to students the differences between the types of fabrics.
3. Obtain volunteers to be blindfolded and recognise the fabric by feel.
4. Describe the fabric by using such words as thick, thin, smooth, rough, heavy, light.
5. Discuss the advantages and disadvantages of various types of fabric.
6. Relate fabric type to flammability.
7. Show some firefighters overalls. Discuss what the overalls are made of.

MAKE THIS TEXTURE BOX.

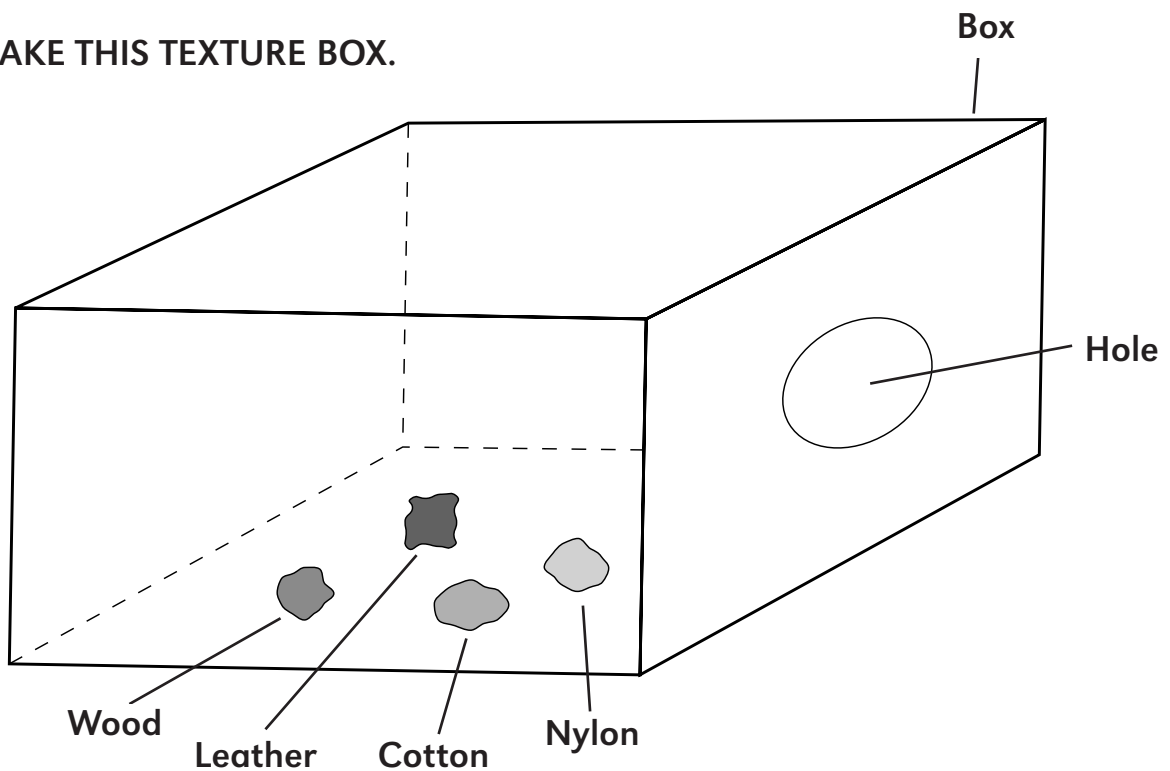

Talk about which types of clothes are fire safe.

# CAMPFIRE SAFETY

1. Only ..... can build campfires. (daluts)
2. Kids can help by collecting ..... (dowo)
3. Campfires are made to cook our ..... (dfoo)  
and to keep us ..... (wmra)

Campfires may be lit during the bush fire danger period provided:

- It is in a properly constructed fireplace with at least 2 metres cleared of any combustible material or at a site where the ground around the fireplace is cleared for at least 3 metres.
- An adult is present.
- There is sufficient water on hand in case of an emergency.
- You ensure that the fire is completely extinguished before leaving the area.



# GETTING ABOUT

# GETTING ABOUT

OUTCOMES	TEACHING STRATEGY	RESOURCES
<p>Recognise the variety of vehicles and other modes of transport used to move loads and people in the local environment.</p>	<ol style="list-style-type: none"> <li>1) Collect pictures of different types of transport.</li> <li>2) Produce a poster displaying various modes of transport.</li> <li>3) Display a variety of matchbox type vehicles.</li> <li>4) Compare, describe and analyse the different ways we travel to school.</li> <li>5) Compare the different ways adults travel to and from their home to go to work, shop and undertake business.</li> <li>6) List the various goods which are transported by road, rail, air and sea.</li> <li>7) Talk about the ways people and goods were moved in the olden days.</li> <li>8) Compare the advantages and disadvantages of various means of transport.</li> <li>9) Count the number of vehicles and their types which pass the school in a set time.</li> </ol>	
<p>Special transport systems</p>	<ol style="list-style-type: none"> <li>1) Recognise special transport systems in the local area (police, fire brigade, ambulance or other services).</li> <li>2) Visit a local service agency (fire, police, ambulance) or have the service visit the school.</li> <li>3) Colour in pictures of a fire truck.</li> <li>4) Recognise the various objects carried on a fire truck.</li> <li>5) Show a variety of toys which represent these transport systems. Make comparisons between the toys and the real vehicles which exist in your local area.</li> <li>6) Compare special structures needed to allow various transport systems to operate (roads, railways, airports, motorways, clearways, passing lanes).</li> </ol>	

# GETTING ABOUT

OUTCOMES	TEACHING STRATEGY	RESOURCES
Construct models.	<p>1) Make a craft material, plasticine or lego model of a “super doopa” car, aeroplane, ship or truck.</p> <p>2) Use model vehicles (matchbox cars/vehicles for example) to simulate the movement of vehicles in a town.</p> <p>3) Construct, on cardboard, a model town with roads, railways, airstrips, fire stations, etc.</p>	
Compare “bush vehicles” with town vehicles.	<p>1) Devise and test an idea about the differences between bush vehicles and town vehicles.</p> <p>2) Recognise the special needs of vehicles used in bush (eg bush fire fighting vehicles)</p> <p>3) Talk about the importance of fire trails.</p>	
Seat belts and car safety.	<p>1) Discuss the importance of wearing seat belts in cars.</p> <p>2) Compile a list of do’s and don’ts about travelling in vehicles.</p>	
Design a modification to the transport system.	<p>1) Talk about how the transport system can be modified.</p> <p>2) Talk about the problems associated with various types of transport (cost, pollution, safety).</p> <p>3) Choose the most appropriate form of transport for transporting goods and people.</p> <p>4) Recognise the limitations of various means of transport.</p> <p>5) Investigate alternative ways to transport fire fighting equipment to a fire (water bombing, water carts).</p>	

Colour in this picture of a fire tanker.

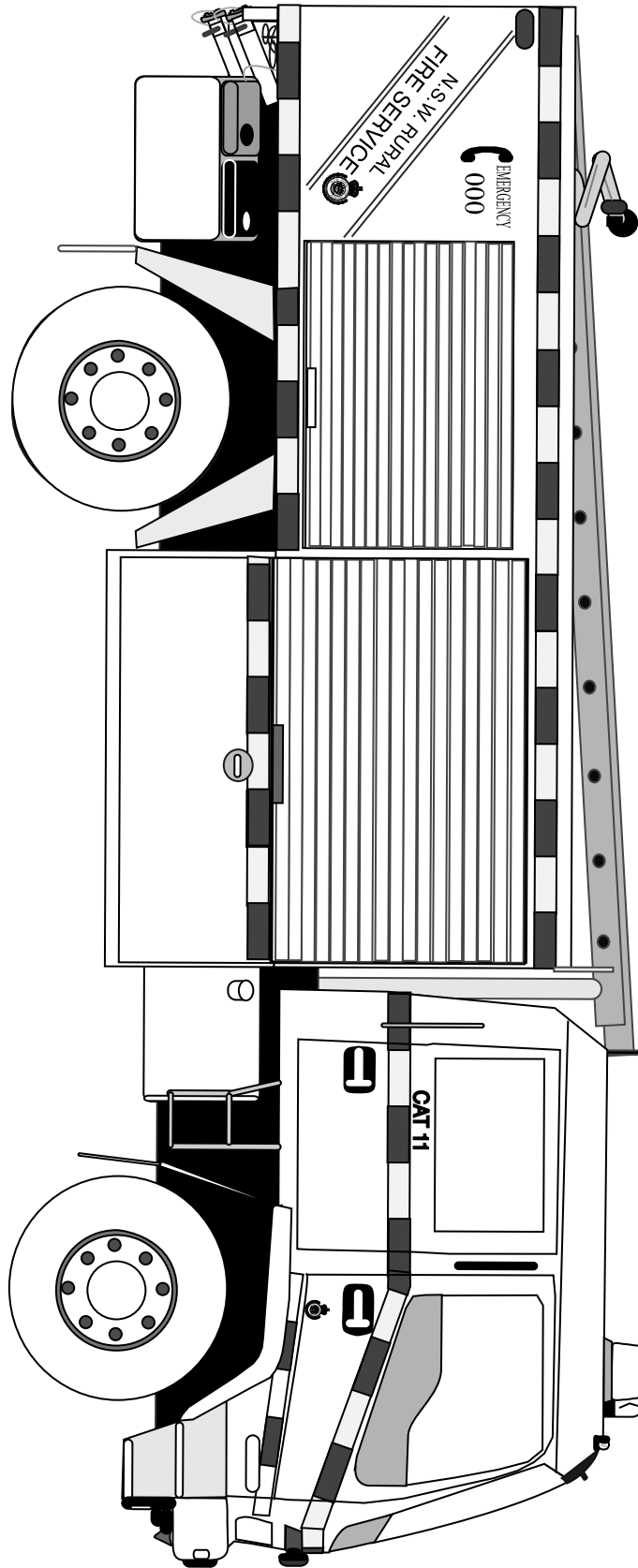



Colour in this picture of a helicopter.

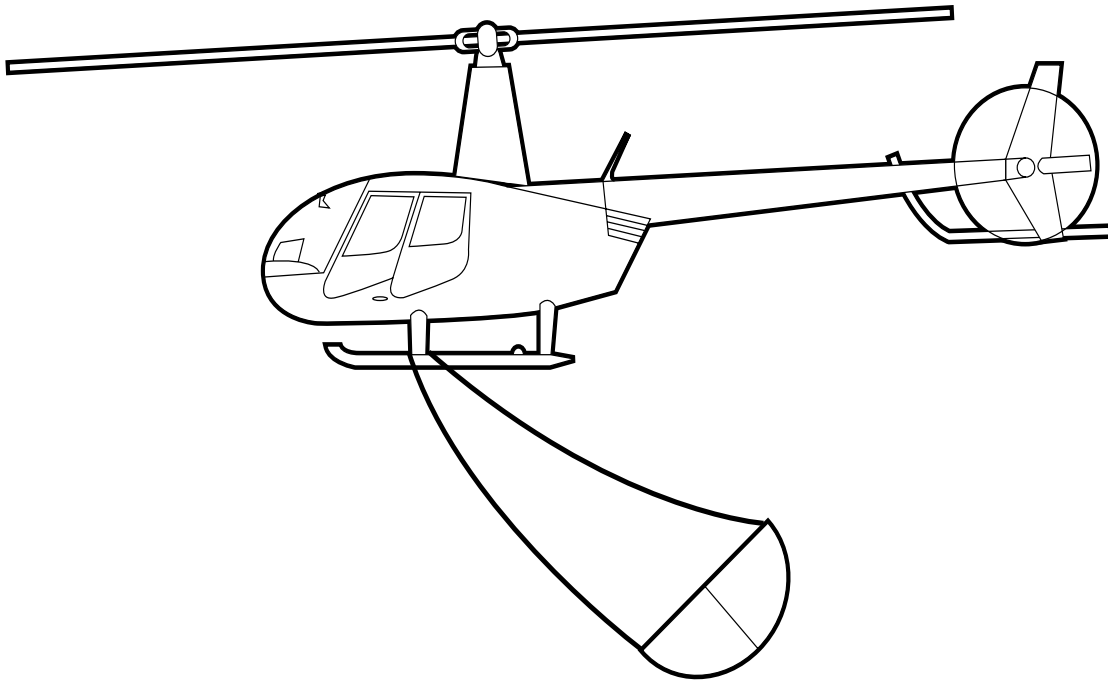

What does this helicopter do? \_\_\_\_\_

\_\_\_\_\_

\_\_\_\_\_

\_\_\_\_\_

\_\_\_\_\_

# CAR SAFETY

Circle the unacceptable actions in this car

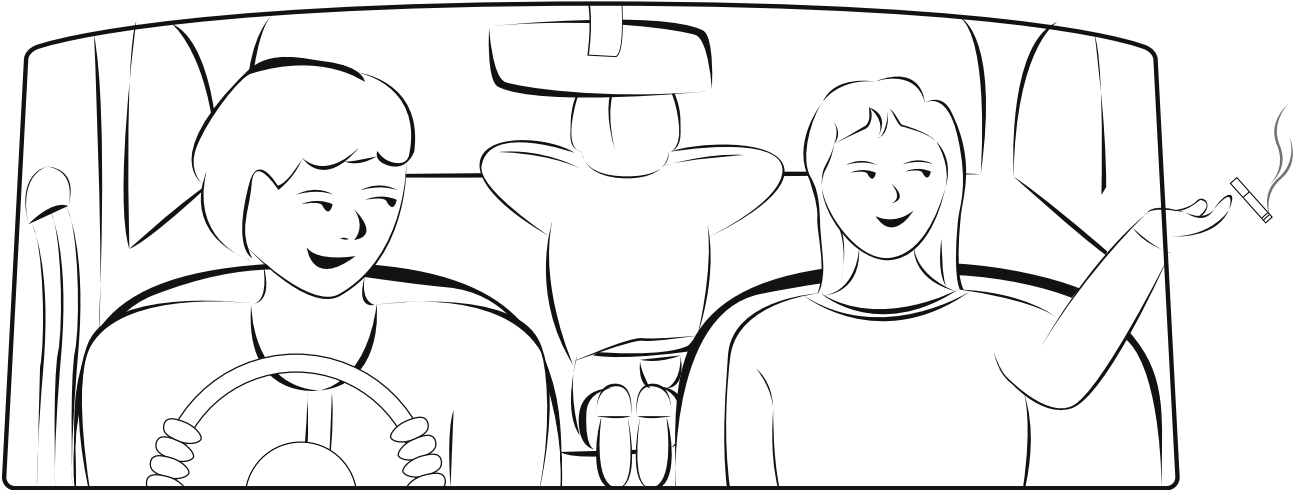

- Write a sentence about what each person is doing incorrectly

---

---

---

- What should people do when travelling in cars or other vehicles?

---

---

---

---

# **GROWING UP AND WHAT IS ALIVE?**

# GROWING UP AND WHAT IS ALIVE?

OUTCOMES	TEACHING STRATEGY	RESOURCES
<p>Recognise that all living things are different.</p>	<ol style="list-style-type: none"> <li>1) Collect a range of pictures showing a variety of living things.</li> <li>2) Discuss similarities and differences between various living things.</li> <li>3) Place pictures of living things into groups according to similar characteristics.</li> <li>4) Examine a variety of preserved specimens of animals.</li> <li>5) Construct a “treasure chest” of living thing bits and pieces (bones, teeth, feathers, insect skeletons, snake skins, plant roots, flowers, seeds, stems).</li> </ol>	
<p>Distinguish between living things and non-living things.</p>	<ol style="list-style-type: none"> <li>1) Compare a living object with a non-living object.</li> <li>2) List the needs of a living object (food, shelter, production of wastes, air, movement, reproduction).</li> <li>3) Describe how the activities of living things affect the environment in which they live - ie. what living things do to satisfy their needs.</li> <li>4) Discuss the nesting and territorial patterns of magpies.</li> <li>5) Snake safety.</li> </ol>	
<p>Design and make a way to satisfy the needs of an animal.</p>	<ol style="list-style-type: none"> <li>1) Map out a model of a fish tank listing all the needs of the fish which are to be placed in it.</li> <li>2) Set up the fish tank as mapped out in the plan.</li> <li>3) Discuss and recognise factors that alter the way in which life exists in the tank.</li> <li>4) Brainstorm the responsibilities of being a pet owner.</li> </ol>	

# GROWING UP AND WHAT IS ALIVE?

OUTCOMES	TEACHING STRATEGY	RESOURCES
Design and use a way to identify the needs of a plant.	<ol style="list-style-type: none"> <li>1) Discuss things needed to make plants grow in the garden.</li> <li>2) Construct a class garden.</li> <li>3) Test the influence of light on germination of wheat seeds grown on cotton wool.</li> <li>4) Design a terrarium in a fish tank. Map out a model of the terrarium listing all of the needs of the plants which are to be placed in the terrarium.</li> </ol>	
Recognise humans as being living things.	<ol style="list-style-type: none"> <li>1) List the things which we need to survive in our environment.</li> <li>2) Collect objects and pictures to show how our needs are satisfied.</li> <li>3) Construct a collage to show how our needs are satisfied.</li> <li>4) Construct flow charts to show where our resources come from.</li> </ol>	
Investigate the diversity of plants and animals in the environment.	<ol style="list-style-type: none"> <li>1) Collect a variety of plants from the playground.</li> <li>2) Recognise the variety of shapes of leaves.</li> <li>3) Collect a variety of pictures of animals.</li> <li>4) Construct a collage showing the diversity of animals in the environment.</li> </ol>	
Recognise that bush fires affect living things.	<ol style="list-style-type: none"> <li>1) Talk about how bush fires affect all living things.</li> <li>2) Collect a variety of Eucalypt seeds.</li> <li>3) Examine the bark of some trees to see how they might be adapted to fire.</li> <li>4) Talk about what animals might do during a fire.</li> <li>5) Talk about what humans should do during bush fires.</li> </ol>	

# PLANTS IN THE BUSH

Make a nature table which has different types of leaves, bark, seeds, stems, flowers.

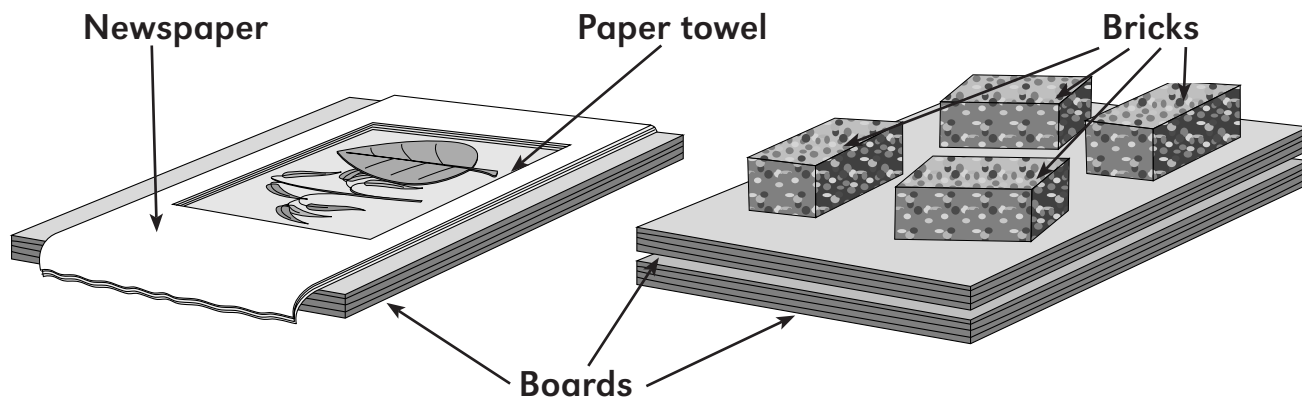

Have a special table which has plant parts from gum trees.

The leaves on a gum tree are \_\_\_\_\_. (hard or soft?)

The seeds on a gum tree are stored in \_\_\_\_\_ (ugm) nuts.

The bark on a gum tree is \_\_\_\_\_. (thick or thin?)

Most gum trees \_\_\_\_\_ (can or cannot) survive bush fires.

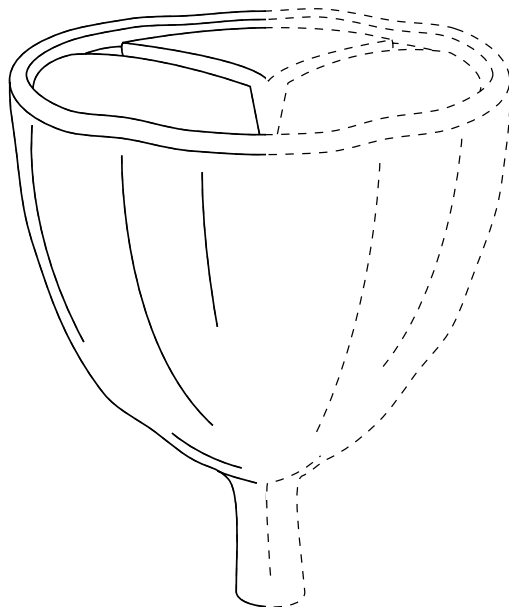

# BUSH FIRE SAFETY PLANTS

P	R	O	T	E	C	T	L	G	S
S	U	R	V	I	V	E	A	N	E
F	L	O	W	E	R	K	M	I	P
N	P	E	E	R	T	C	I	V	A
E	L	L	K	S	D	I	N	I	H
E	A	E	R	T	E	H	A	L	S
D	N	A	A	E	E	T	P	W	F
S	T	F	B	M	S	R	O	O	T
H	A	R	D	E	R	I	F	R	U
G	U	M	G	R	L	J	R	G	N

- |         |         |       |        |
|---------|---------|-------|--------|
| ANIMAL  | BARK    | FIRE  | FLOWER |
| GROW    | GUM     | HARD  | LEAF   |
| LIVING  | NEEDS   | NUT   | PLANT  |
| PROTECT | ROOT    | SEED  | SHAPES |
| STEM    | SURVIVE | THICK | TREE   |

# BUSH FIRE SAFETY

Practise these exercises in the school ground or when out on excursions.

If you are in the bush and a fire starts it is important not to **panic**. Do not **run**. **Stop** and **think**.

Do not run uphill. Look for an **open space**. Find a ditch or other **low spot**, or get close to a **rock**, bank or fallen **tree**.

**Lie** face down as low as possible. **Cover** your skin.

Kids should not go into the **bush** on their own. There should always be an **adult** with them.

The words in bold are hidden in this puzzle.

A	D	U	L	T	R	E	V	O	C
H	E	C	A	P	S	T	T	B	S
C	P	A	N	I	C	H	R	A	T
T	B	U	S	H	E	I	E	N	O
I	S	K	I	N	I	N	E	K	P
D	R	O	C	K	L	K	T	W	C
O	P	E	N	E	R	I	F	O	A
R	U	N	M	C	I	L	R	L	Q



# HOT AND COLD

# HOT AND COLD

OUTCOMES	TEACHING STRATEGY	RESOURCES
<p>Recognise hot and cold areas of the classroom and at home.</p>	<ol style="list-style-type: none"> <li>1) List the places in the classroom which are hot, warm and cool.</li> <li>2) List places and objects which are hot, warm, cool and cold at home.</li> <li>3) Construct signs to show that an object is hot or cold.</li> <li>4) Place signs around the room to signify areas of different temperatures.</li> <li>5) Recognise signs and symbols that are used to show that something is hot or cold.</li> </ol>	
<p>Classify fires as being good or bad fires.</p>	<ol style="list-style-type: none"> <li>1) Recognise the ways in which humans use fire to help them do things.</li> <li>2) Discuss the variety of fuels we use to make things burn.</li> <li>3) Compare “good” and “bad” fires.</li> <li>4) Compare the use of fires in different societies.</li> <li>5) Recognise the need for kids to stay away from fire.</li> </ol>	
<p>Understand correct procedures for handling hot objects.</p>	<ol style="list-style-type: none"> <li>1) Practise correct techniques for touching objects to see if they are hot or cold.</li> <li>2) Observe and practise the correct procedure for lifting or moving hot objects.</li> <li>3) Observe and practise the correct procedure for running hot and cold water.</li> </ol>	
<p>Recognise the correct procedure for cooling a burn.</p>	<ol style="list-style-type: none"> <li>1) Practise the correct procedure for cooling a burn.</li> <li>2) Recognise things that can cause a burn.</li> <li>3) Recognise the things that can be used to cool a burn.</li> </ol>	

# HOT AND COLD

OBJECTIVES	TEACHING STRATEGY	RESOURCES
<p>Recognise safe procedures we should observe around heating devices.</p>	<ol style="list-style-type: none"> <li>1) Recognise and name various heating devices used in the home.</li> <li>2) Compare the heating devices used in different societies.</li> <li>3) Discuss how heating devices can burn things.</li> <li>4) Discuss and practise techniques for minimising injury from hot things.</li> <li>5) Practise STOP, DROP, COVER and ROLL.</li> <li>6) Develop a set of safety procedures associated with match and lighter use.</li> <li>7) Recognise matches and lighters as tools used by adults.</li> </ol>	
<p>Develop sun safe practices.</p>	<ol style="list-style-type: none"> <li>1) Describe the effects of sunburn.</li> <li>2) Understand how sunburn can be prevented.</li> <li>3) Practise the correct procedure for applying sun screen.</li> <li>4) Encourage the wearing of hats.</li> </ol>	
<p>Develop an understanding of the concept of insulation.</p>	<ol style="list-style-type: none"> <li>1) Discuss how we keep our food and drinks warm or cold.</li> <li>2) Discuss how we keep ourselves warm and cool.</li> <li>3) Discuss how other animals keep themselves warm and cool.</li> <li>4) Collect a variety of clothing materials.</li> <li>5) Understand that some clothes burn more easily than others.</li> </ol>	

# HOW TO COOL A BURN

If you burn your hand:

Do you do this?



Or this?



Colour the correct way.

If we burn our hand we must cool it straight away. If we do not cool it the burn will get worse.

We must:

**COOL A BURN WITH COOL WATER FOR 10 -15 MINUTES.**

**TELL AN ADULT.**

**DO NOT PUT CREAMS ON THE BURN.**

Collect some pictures out of old magazines of things that could burn you.

Write the names of some of the things that burn.

---

---

# SIGNS

Use these letters to make signs which say:

HOT COLD WARM COOL.

L L L L L W W W W W

T T T T T R R R R R

O O O O O H H H H H

O O O O O A A A A A

O O O O O D D D D D

O O O O O C C C C C

L L L L L M M M M M

C C C C C

Place the signs around the room to show the hot, cold, warm,  
and cool parts of the room.

Choose the word from the box which matches the picture.

IRON TAP PLUG CUP

If the object in the picture is hot or could cause a fire, colour it red.

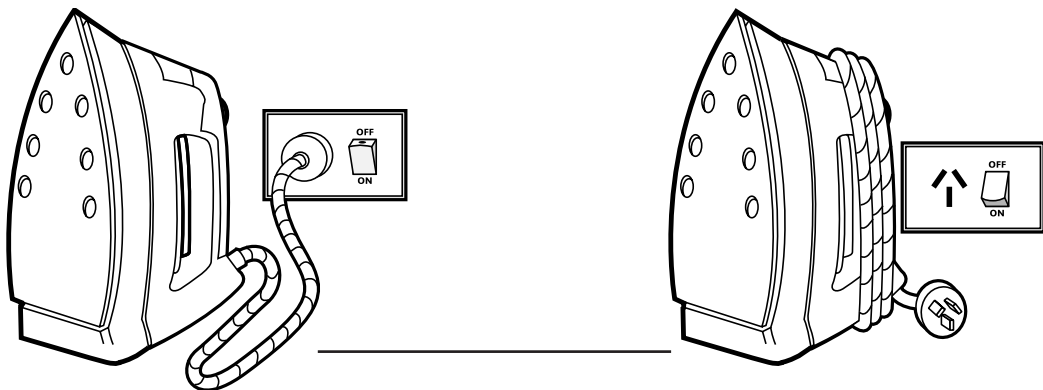
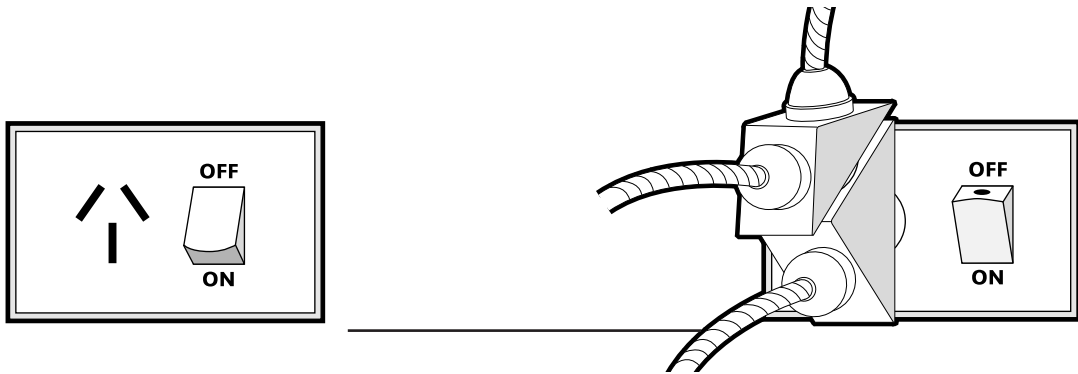
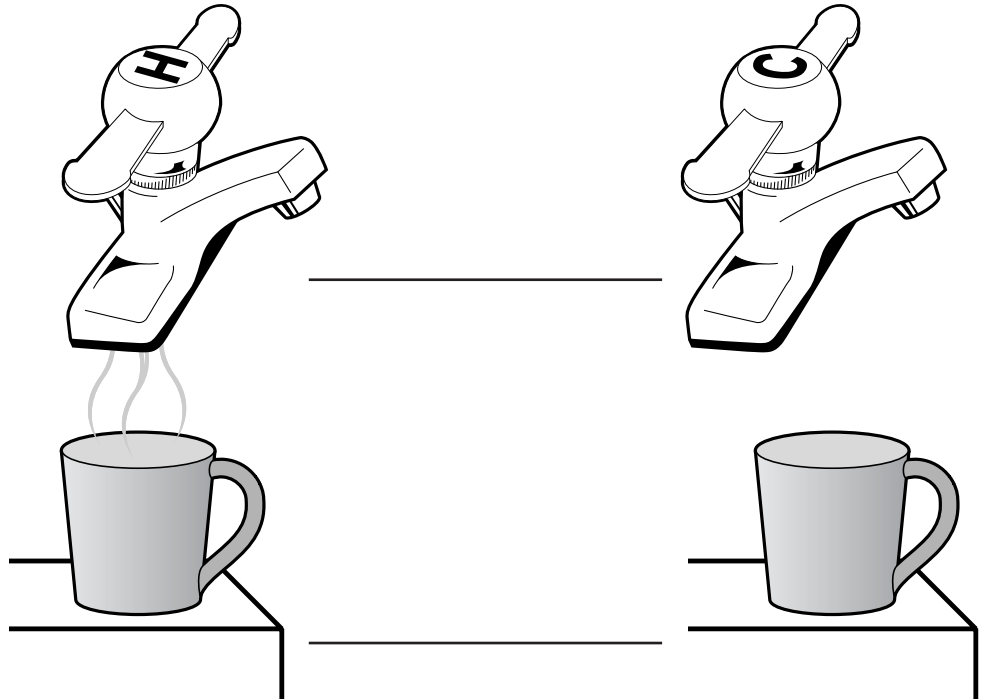

# HOT AND COLD TAPS

## HOT TAPS.

Put signs on top of these taps to show which is hot and which is cold.

There are two hot and two cold. (Use different signs and symbols for each tap).

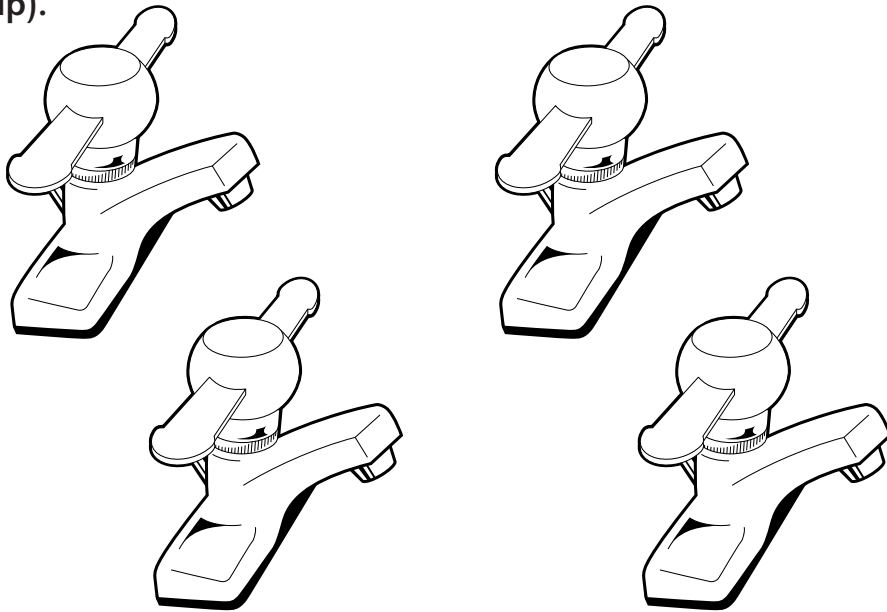

Talk about how water should be run into the bath.

Write down some of your ideas.

- \_\_\_\_\_
- \_\_\_\_\_
- \_\_\_\_\_

Talk about ways to find out how hot water is.

Write down some of your ideas.

- \_\_\_\_\_
- \_\_\_\_\_
- \_\_\_\_\_

# GOOD FIRES AND BAD FIRES

Fires can be used to help us. These are good fires.

Talk about and write some things that fires do to help us.

- \_\_\_\_\_
- \_\_\_\_\_
- \_\_\_\_\_

Fires can do things to hurt us. These are bad fires.

Talk about and write down some things that fires do to hurt us.

- \_\_\_\_\_
- \_\_\_\_\_
- \_\_\_\_\_

Use this word bank to complete the sheet about good fires and bad fires.

candles    out    barbecue    burn  
bush    heater    fire    fires



# GOOD FIRES - BAD FIRES ACTIVITY

On my birthday I have a cake with...



\_\_\_\_\_ on it

In summer, we cook sausages on the...

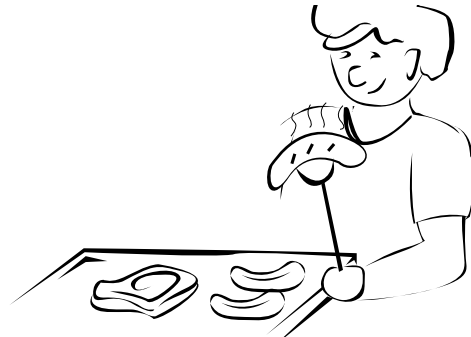

\_\_\_\_\_.

When it's cold, we sit in front of the gas...

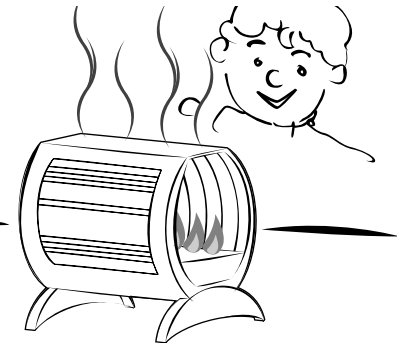

\_\_\_\_\_ to keep warm.

Unattended camp fires causes bush...

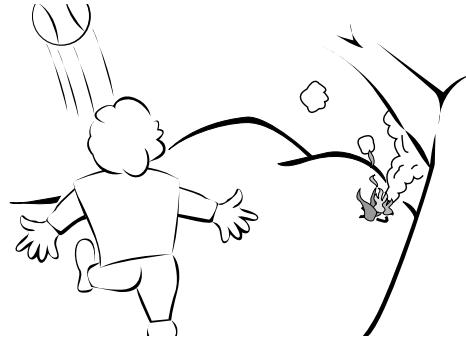

\_\_\_\_\_.

If you leave the bread in the toaster too long

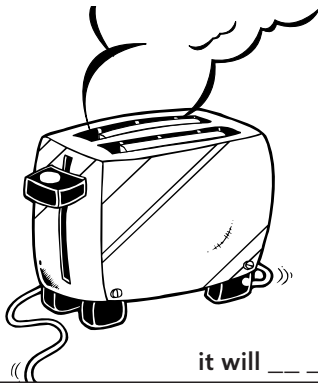

it will \_\_\_\_\_.

Put camp fires

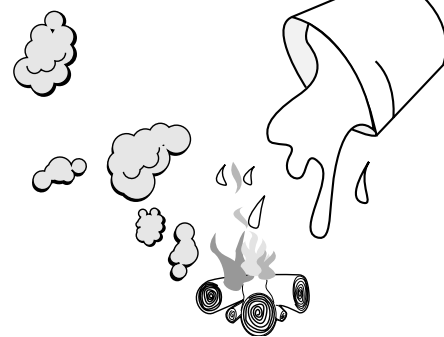

\_\_\_\_\_ before leaving the camp area.

Too many plugs in a power point cause...

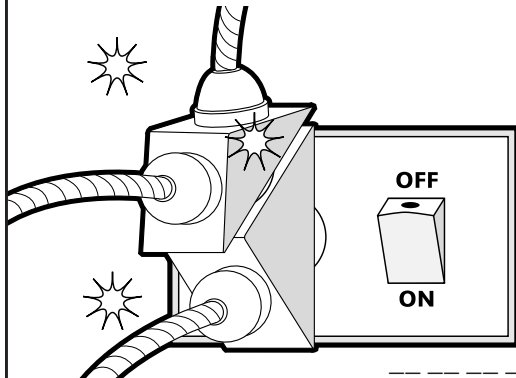

\_\_\_\_\_.

On hot days we have big...

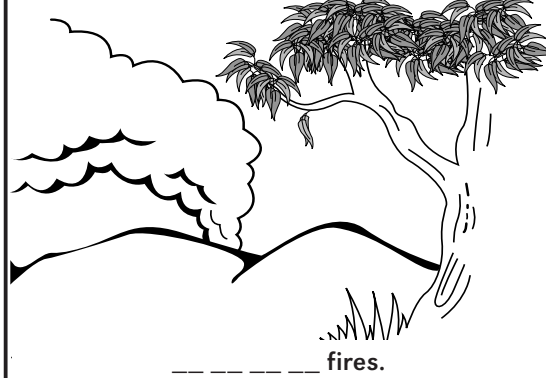

\_\_\_\_\_ fires.

# HOT STUFF

H	E	U	C	E	B	R	A	B	F
E	S	C	A	L	D	T	U	O	I
A	K	M	N	E	M	A	L	F	R
T	O	E	D	E	K	O	M	S	E
E	O	L	L	M	A	E	T	S	S
R	C	T	E	W	A	T	E	R	T
F	W	A	S	T	R	U	H	T	O
I	W	A	R	M	B	U	R	N	H
R	H	S	U	B	O	I	L	S	E
E	R	A	C	S	L	O	O	C	R

BARBECUE

BOILS

BURN

BUSH

CANDLES

COOK

COOL

FIRE

FIRES

FLAME

HEATER

HOT

HURT

MELT

OUT

SCALD

SCAR

SMOKE

STEAM

WARM

WATER

Use the letters that are left to finish this sentence.

“If you burn your hand you must cool it with \_\_\_\_\_”

Finish these sentences by choosing the best word  
in the brackets. Circle the word you choose.

1. Kids should stay away from fires because fires cause (burns/  
bruises).
2. Boiling water can tip onto your skin and cause (scalds/scratches).
3. If we play with fire we could cause (butterflies/bush fires) or we  
could burn our (house / horse).
4. Our clothes could catch (cold / fire) if we play with matches.
5. If we burn ourselves we must cool it with (butter / water).
6. We use fires when we go (carpet / camping).
7. My hair will burn if I get too close to my birthday (cake / candles).
8. We use fire to (cook / catch) our food. We also use fire to keep us  
(warm / rich). Fire is sometimes used to give us (energy / light).

# IF YOU ARE CAUGHT IN A BUSH FIRE

You should not be in the bush on your own!!!!

However, if you ever get caught in a bush fire you must remember to:

STOP

DROP

COVER UP

If your clothes catch fire you must remember to:

STOP

DROP

cover

ROLL

Shade "stop" in red, "drop" in blue and  
"cover up" in yellow and roll in green.

# STOP, DROP, COVER UP

- Write a sentence to say what is meant by STOP.

---

- Write a sentence to say what is meant by DROP.

---

- Write a sentence to say what is meant by COVER UP .

---

- Where is the best place to stop and drop?

---

- What things could be used in the bush to cover up?

---

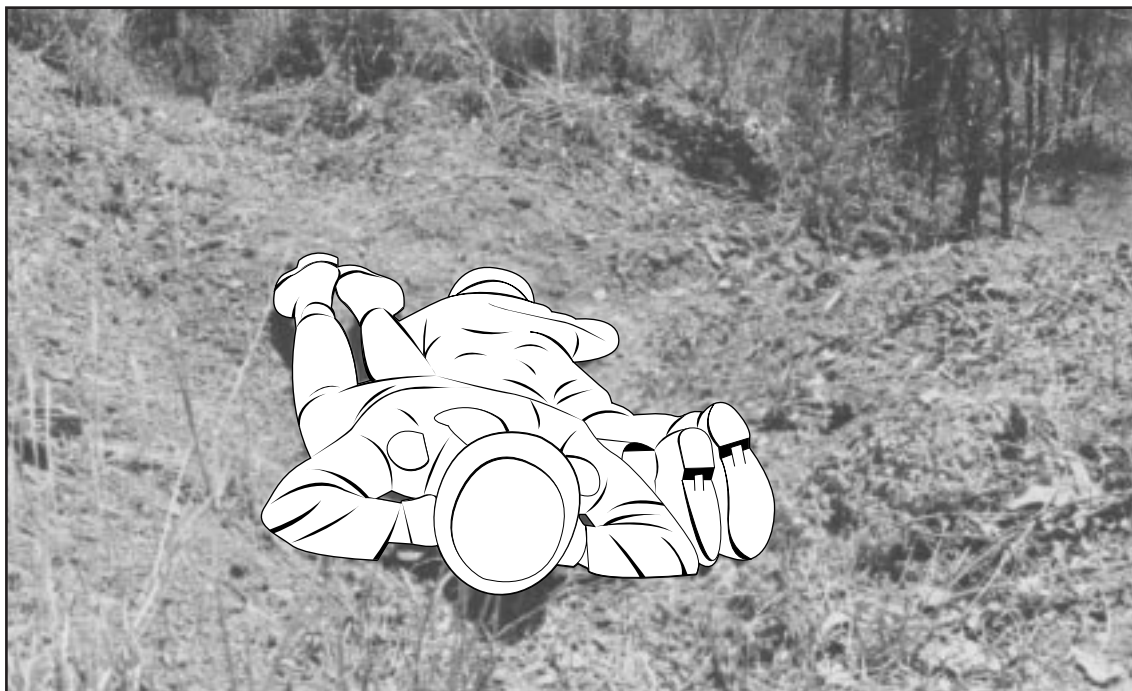

# STOP, DROP AND ROLL

PRACTICE THIS:

**STOP** where you are.

**DROP** onto the ground.

**COVER** cover your face with your hands.

**ROLL** over several times.

If your clothes are on fire and you run around you are going to fan the flames. Standing still (or stopping) stops the fire from spreading.

When we drop, the flames cannot spread as fast. Cover your face with your hands. This will protect your face.

Rolling smothers the fire. Keep rolling until the fire is out.

**What would you do if someone else's clothes were on fire?**

- I would tell them to \_\_\_\_\_

**How could you help them?**

- I could help them but I would have to be careful not to \_\_\_\_\_

# STOP, DROP AND ROLL

MATCH EACH OF THE PICTURES WITH THE CORRECT LABEL.

STOP

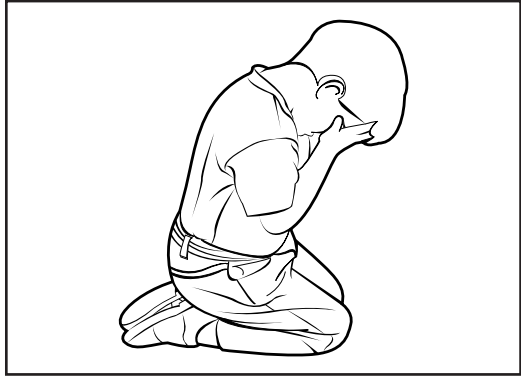

DROP  
COVER

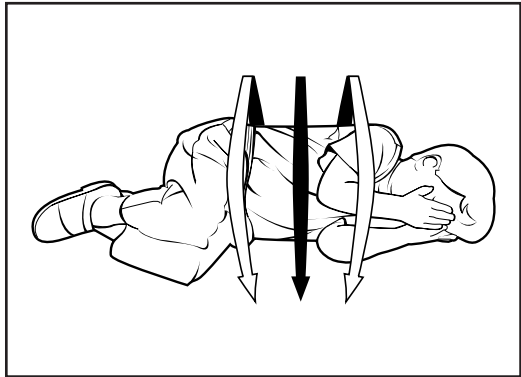

ROLL

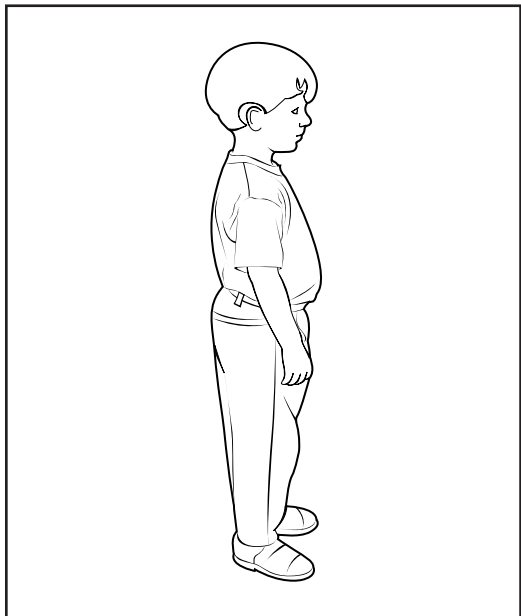

**MATCH THE FOLLOWING WORD BEGINNINGS  
WITH THE CORRECT WORD ENDINGS.**

<b>WORD START</b>	<b>WORD ENDING</b>
ST	LL
DR	ER
RO	SH
COV	RN
FLA	OP
BU	KE
HE	OK
SMO	ME
BU	OP
CO	AT

Answer true or false:

1. We should run away if our clothes start burning. \_\_\_\_\_
2. Rolling puts out the flames. \_\_\_\_\_
3. A blanket would be good to cover the flames. \_\_\_\_\_
4. Butter makes burns better. \_\_\_\_\_
5. If we are burning we should stop, drop, cover up and roll. \_\_\_\_\_
6. A shallow hole can protect us from bush fire. \_\_\_\_\_



# MATCHES AND SAFETY

We use ma\_\_che\_\_ to start a fire.

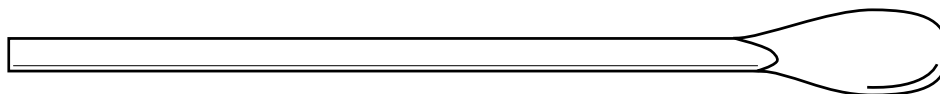
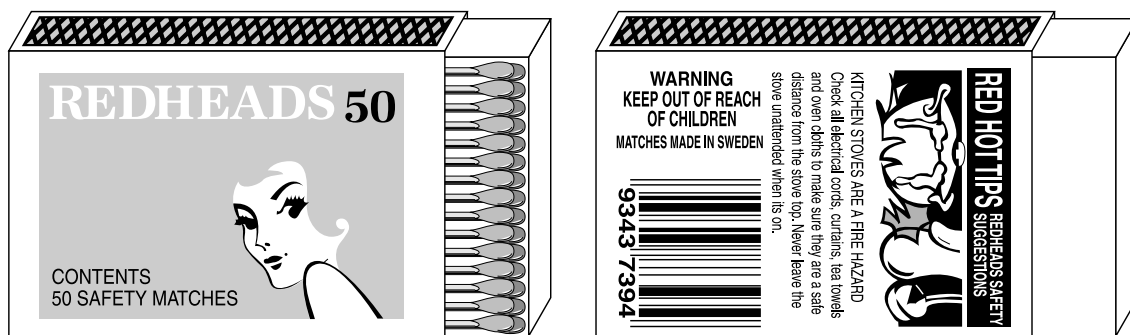

Fill in the blank letters to write the warning which is on the back of the box.

WARNING: K \_\_\_ P OUT OF REA \_\_\_ OF CHILD \_\_\_

Who should be using matches in your home? \_\_\_\_\_

\_\_\_\_\_

How many matches are in the box?

\_\_\_\_\_

The matches are made from woo\_\_

Do all surfaces of the box feel the same?

YES or NO

On the diagram of the match box label the parts which are **smooth** and the parts which are **rough**.

Colour in the match box.

Collect some empty match boxes from home. See if they have a FIRE SAFETY message. Get your teacher to photocopy any of the fire safety messages.



Colour in this fire safety message that was on this matchbox.

# MATCHES ARE NOT TOYS

Use the word bank to complete each of the following sentences.

- This is a \_\_\_\_\_.

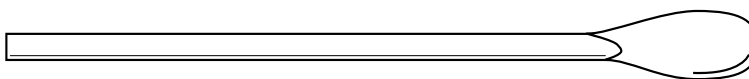

- Matches are kept in a \_\_\_\_\_.



- Only \_\_\_\_\_ should use matches.

- Matches should be stored away from \_\_\_\_\_.

- If we play with matches we could start a \_\_\_\_\_ fire.

- Matches are not toys, they are \_\_\_\_\_.

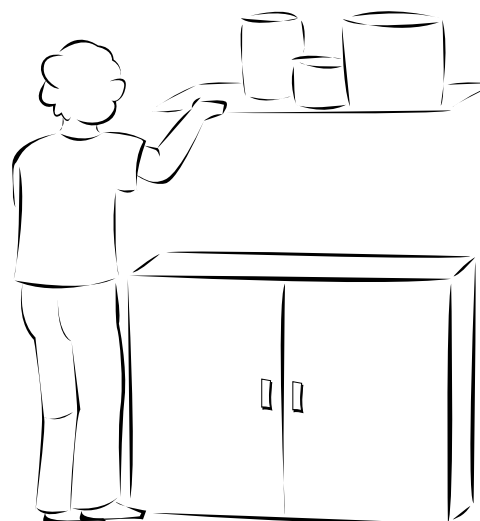

tools    kids    adults    bad    match    box

# LET'S BOIL THE BILLY

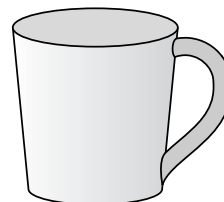
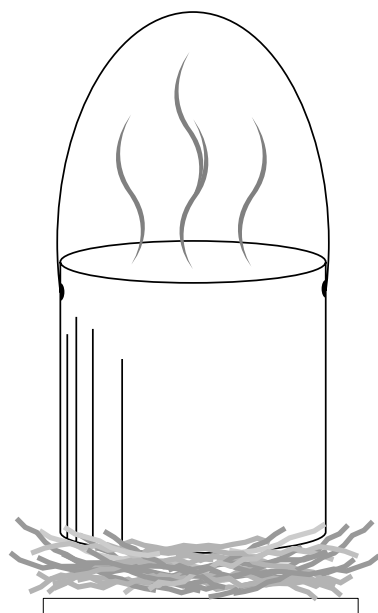

**DRAW IN AND COLOUR THE FLAMES NEEDED TO MAKE THE BILLY BOIL.**

How long does it take to boil? (make a clock face from paper plates)

The time when I start.

The time when it boils.

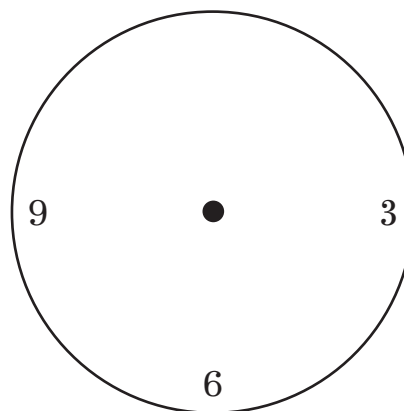
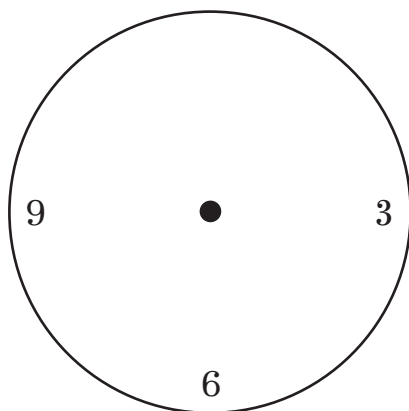

**Place the minute dots on the diagram and draw the hour hands and the minute hands.**

The billy took ..... minutes to boil.

How can you make the water boil quicker?

big sticks	or	small sticks
blow onto the flames	or	do not blow onto the flames
lots of water in the billy	or	less water in the billy
black billy	or	shiny billy

(circle the correct response)

What can you do to stop the fire getting away?

---



---

**DO THESE THINGS BURN?**

FUEL	Burns (yes or no)
paper	
wood	
cement	
glass	
wire	
steel wool	
wax	
wool	
coal	

# THINK FIRE SAFE

E	L	D	N	A	C	A	D	U	L	T	S	R	E	E
M	A	T	C	H	T	O	O	L	S	N	L	E	R	K
A	R	E	V	O	C	G	O	E	D	R	A	P	O	O
L	S	Y	O	T	Y	O	Q	U	R	U	O	A	T	M
F	K	I	D	S	T	O	P	F	O	B	C	P	S	S
E	F	A	S	K	Q	D	D	B	P	L	L	O	R	X
T	A	E	H	O	M	R	A	W	O	I	L	Q	P	O
A	N	P	R	O	U	S	B	Y	H	L	N	G	Q	B
N	F	A	S	C	F	S	D	W	O	O	D	M	H	Y

ADULTS

BAD

BOX

BURN

CANDLE

COAL

COOK

COVER

DROP

FLAME

FUEL

GOOD

HEAT

HOT

KIDS

MATCH

OIL

PAPER

ROLL

SAFE

SMOKE

STOP

STORE

TOOLS

TOYS

WARM

WOOD

# BURNING CANDLE



Draw what you see when the candle burns.

Are candles dangerous? \_\_\_\_\_

Are they good fires or bad fires? \_\_\_\_\_

How does the wax change?

It m \_\_ l \_\_ s

What could you put under the candle to make it safe?

\_\_\_\_\_

How can you put the candle out?

\_\_\_\_\_

Draw the number of candles which show your age.

# WHAT WOULD YOU DO IF:

Circle the correct answer.

## 1) You burnt yourself?

- Put butter on it.
- Call out for mum or dad.
- Put the burnt part under cool water.



## 2) Your clothes catch on fire?

- Run outside.
- Stop drop cover and roll.
- Call out for mum or dad.

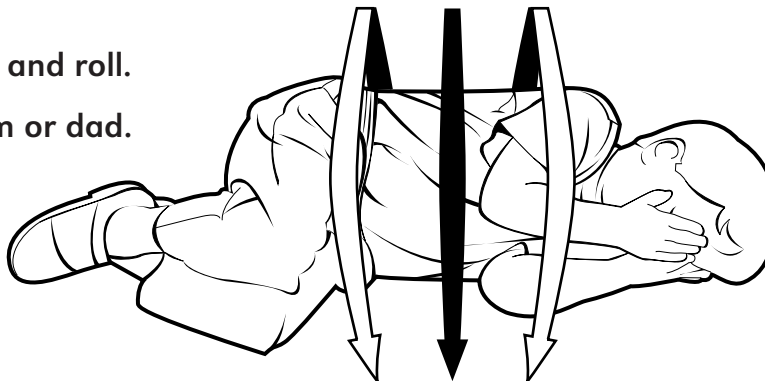

## 3) You are caught in a smoke filled room?

- Call out for mum or dad.
- Stop drop and roll.
- Keep low and crawl out of the room.





# KIDS CARE

# KIDS CARE

Outcomes	TEACHING STRATEGY	RESOURCES
<p>Investigate the effect people and things have on the environment.</p>	<p>1) List the variety of things that people do in the local environment.</p> <p>2) Discuss how the natural environment has to be changed to allow people to do their jobs.</p> <p>3) List and discuss the various ways weather alters the environment (floods, fires, droughts).</p>	
<p>Compare the natural environment with the built environment.</p>	<p>1) Discuss how the local environment may have changed over the last 200 years to accommodate the built environment.</p> <p>2) Ask an older person to tell you about the environment in passed years.</p>	
<p>Develop a sense of responsible use and recycling of materials.</p>	<p>1) Collect a variety of materials that we use during a day.</p> <p>2) Develop a recycling bin at school and at home.</p> <p>3) Discuss the appropriate way to dispose of rubbish.</p> <p>4) Develop a poster to discourage people from burning rubbish.</p> <p>5) Investigate what happens to materials when left in the environment.</p> <p>6) Design and make packaging for a gift that is environmentally friendly.</p>	

**LET'S COMMUNICATE**

# LET'S COMMUNICATE AND OUR SENSE OF DIRECTION

Outcomes	TEACHING STRATEGY	RESOURCES
<p>Locate and name the various parts of our body used to communicate.</p>	<ol style="list-style-type: none"> <li>1) Match messages sent and received with the various senses involved.</li> <li>2) Categorise messages as visual, sound, chemical, touch.</li> </ol>	
<p>Recognise signs and symbols used in our environment.</p>	<ol style="list-style-type: none"> <li>1) Locate and recognise various signs that exist in the school environment.</li> <li>2) Construct and place various signs in the room to indicate different activity areas.</li> <li>3) Identify the circumstances that necessitate a message.</li> <li>4) Identify, locate and specify the purpose of various signs and symbols used in the local community.</li> </ol>	
<p>Recognise uniforms that are worn by different people in the environment.</p>	<ol style="list-style-type: none"> <li>1) List various types of people who wear uniforms in the community.</li> <li>2) Relate the uniform with the function of that person.</li> <li>3) Colour in pictures of firefighters. Recognise the uniform of a firefighter.</li> </ol>	
<p>Recognise sounds that communicate a message to us.</p>	<ol style="list-style-type: none"> <li>1) List the variety of sounds that give us information (bells, sirens, etc.).</li> <li>2) Recognise the sound made by a smoke alarm.</li> <li>3) Recognise the schools fire alarm and react accordingly.</li> <li>4) Compare the sounds made by various musical instruments.</li> <li>5) Visit or invite members of the Rural Fire Brigade to visit the school. Ask to listen to the siren.</li> </ol>	

# LET'S COMMUNICATE AND OUR SENSE OF DIRECTION

OUTCOMES	TEACHING STRATEGY	RESOURCES
Develop a knowledge of the correct procedure to be used when using the telephone.	1) Practise using the telephone. 2) Practise dialling numbers. 3) Know how to use the telephone to report a fire.	
Investigate the ways in which humans communicate non-verbally.	1) Recognise various facial expressions that portray a message. 2) Construct masks to show sad, happy, etc.	
Investigate devices which help our senses gather information about our environment.	1) Observe devices that enable sounds to be louder. 2) Investigate how messages can be sent over large distances.	
Investigate how other living things communicate.	1) Compare the senses of different animals. 2) Give examples of how different animals use different senses to communicate.	

## SIGNS 2

Change the letters in the sign so that it spells a way out.

**XTIE =**

You see these two scrambled words on doors.

They tell you how to open the door.

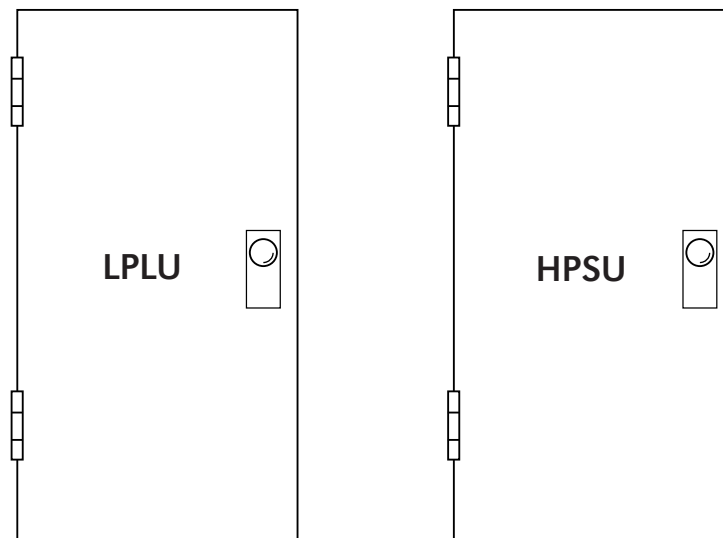

What do the unscrambled letters say?

-----

The scrambled words on the following sign tell you how to go into a building.

**RENET =**

# SMOKE ALARMS

We have ..... smoke alarms in my house.

When the smoke alarm goes off it makes this sound.

B \_ \_ \_ \_ \_    \_ \_ E \_ \_ \_ \_    \_ \_ \_ E \_ \_  
\_ \_ \_ \_ \_ P    B \_ \_ \_ \_    BEEP.....

Colour in the picture of the smoke alarm and fill in the blank letters.

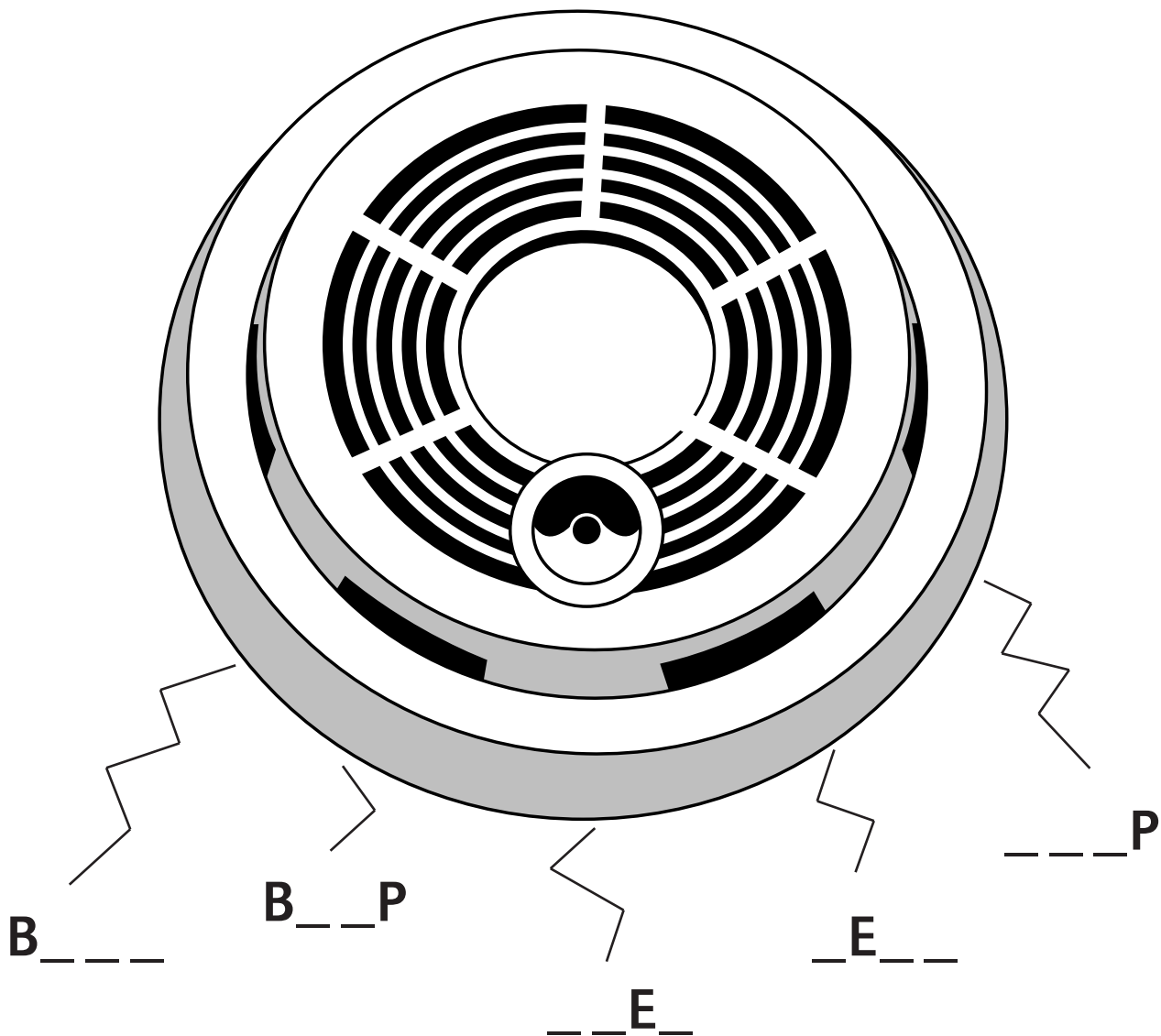

# HOW TO

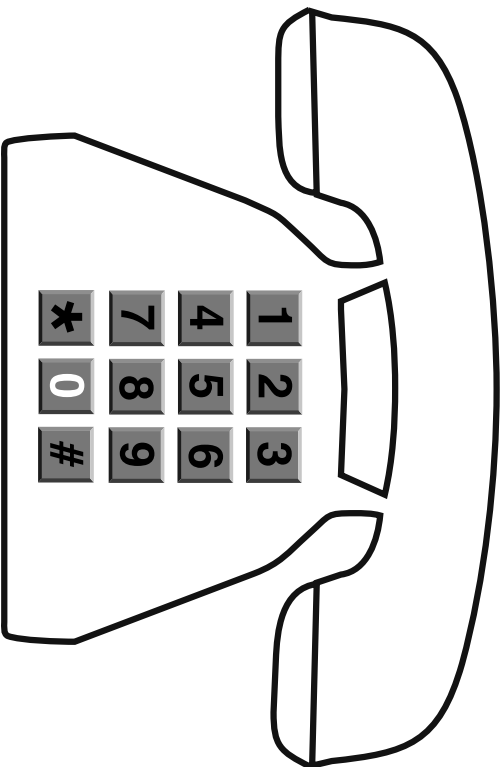

# RING

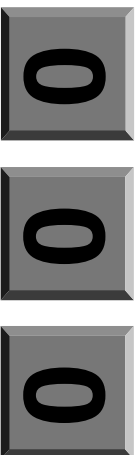

# GIVE

- ✓ Your name
- ✓ Your address
- ✓ The nearest corner street
- ✓ Where the fire is

# REPORT FIRES



# LOOK AROUND YOU

# LOOK AROUND YOU

OUTCOMES	TEACHING STRATEGY	RESOURCES
<p>Investigate the use of spaces at school and at home.</p>	<ol style="list-style-type: none"> <li>1) Locate on a plan of your school the places where we learn, rest, eat, drink, be quiet and play.</li> <li>2) Investigate the special features of various areas at school.</li> <li>3) Draw a simple plan of your house and locate the various rooms.</li> <li>4) List the characteristic features of some of the rooms in your house.</li> </ol>	
<p>State the purpose of emergency routines at school and at home.</p>	<ol style="list-style-type: none"> <li>1) Locate fire blankets and fire extinguishers at school and at home.</li> <li>2) Talk about the importance of having this equipment.</li> <li>3) Develop a home escape plan.</li> <li>4) Practise emergency fire drills at school.</li> <li>5) Recognise problems associated with getting out of buildings during fires.</li> </ol>	
<p>Recognise how the school space changes.</p>	<ol style="list-style-type: none"> <li>1) List variable factors that occur at school (sunshine, shadows, light, furniture density, temperatures, noisy, quiet).</li> <li>2) Measure temperature and light variations in the room.</li> <li>3) Investigate high traffic areas in the room.</li> <li>4) Relate changes that occur in the room to the time of day.</li> <li>5) Determine ways variables in the room can be controlled (curtains, furniture placement, seating etc.).</li> <li>6) Draw up a list to balance pleasant and not so pleasant aspects of the room.</li> <li>7) Relate the classroom environment to specific classroom needs.</li> </ol>	

# LOOK AROUND YOU

OUTCOMES	TEACHING STRATEGY	RESOURCES
<p>Use our senses to explore and map the school environment.</p>	<ol style="list-style-type: none"> <li>1) Recognise various areas of the school ground by feel, textures, sounds and smells.</li> <li>2) Blindfold students and have them identify different areas using their other senses.</li> <li>3) Recognise various places in towns which have specific sounds and smells.</li> </ol>	
<p>Use models to plan a different environment.</p>	<ol style="list-style-type: none"> <li>1) Draw the ideal home.</li> <li>2) Draw the ideal classroom.</li> <li>3) Design the ideal play area.</li> <li>4) Compare different models and discuss advantages and limitations of each model.</li> <li>5) Collect house pictures from a newspaper and talk about why you would or would not live in various homes.</li> <li>6) Collect samples of different types of materials used in building construction.</li> <li>7) Talk about things that might be a fire hazard.</li> </ol>	

# HOME ESCAPE PLAN

1. WHERE I SL\_\_\_ P.

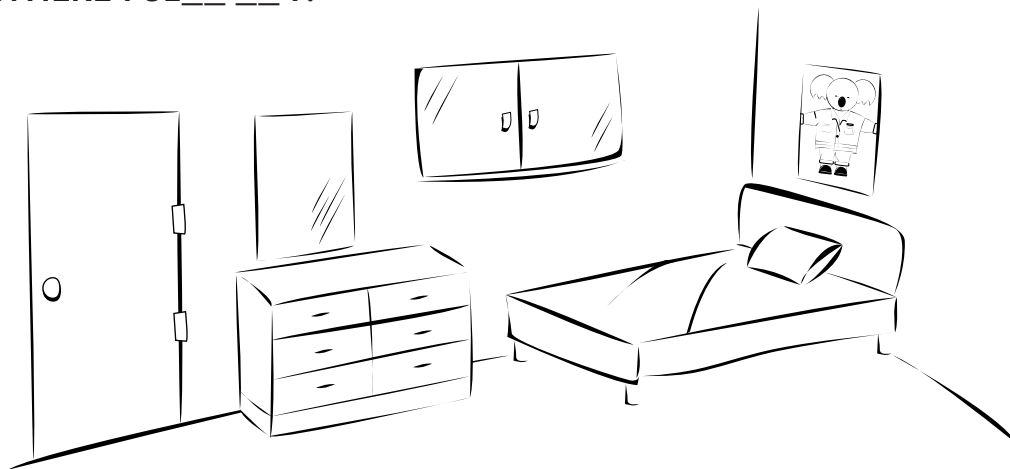

2. Two ways out of the space where I sleep are:

wi\_\_ d\_\_\_\_\_

d\_\_\_\_\_ r

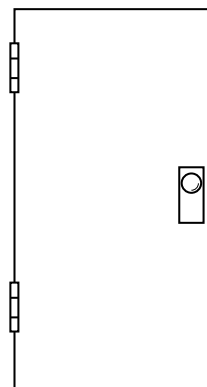
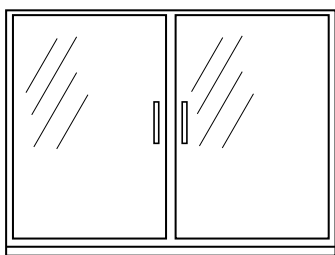

3. Three things to do.

- get out
- get help
- stay out

4. Go to your MEETING PLACE.

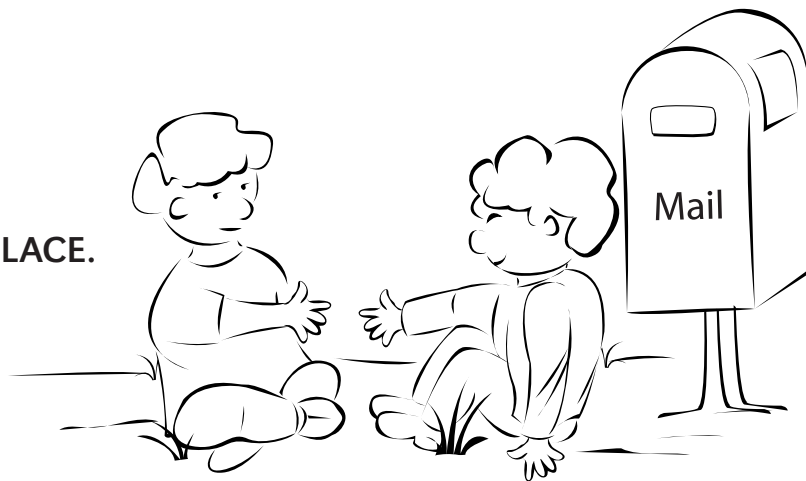

# GET DOWN LOW AND GO! GO! GO!

Colour in the picture which shows you what you should do if you are caught in a room that is full of smoke.



When you get down low and GO! GO! GO!, Where will you GO to?

---

---

When you get out, where will you go to?

---

---

---

# HELP SMOKEY ESCAPE FROM THE FIRE IN HIS HOUSE

There is a fire in Smokey's house. Smokey has to get down low and GO GO GO to his meeting place. Trace the path that Smokey could take. (Hint: There is more than one way out. Try to find all of the ways out.)

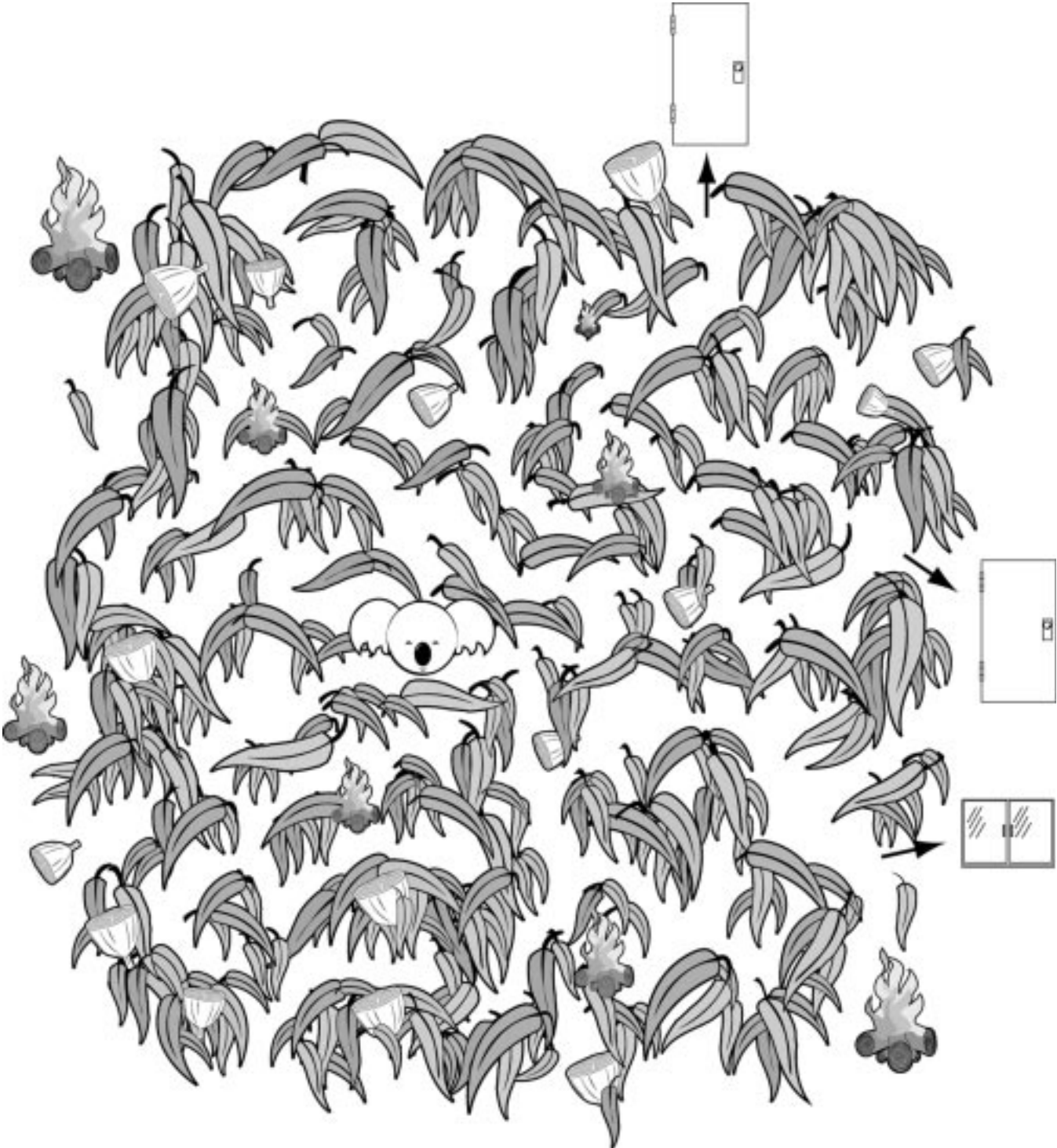

# HOUSE ESCAPE PLAN

E	N	T	E	R	L	L	I	R	D
S	C	R	A	W	L	S	T	O	P
C	E	K	O	M	S	D	R	O	P
A	C	O	V	E	R	L	T	P	U
P	B	E	E	P	S	L	I	U	S
E	L	L	A	C	A	O	X	L	H
N	M	E	E	T	F	R	E	L	W
A	O	O	O	U	E	B	E	E	O
L	P	B	E	O	E	P	B	E	L
P	E	P	A	L	A	R	M	P	B

These words are hidden in the puzzle.  
The letters left over are the sound made by a smoke alarm.

- |        |       |      |       |
|--------|-------|------|-------|
| ALARM  | BEEP  | CALL | COVER |
| CRAWL  | DRILL | DROP | ENTER |
| ESCAPE | EXIT  | LOW  | MEET  |
| OOO    | OUT   | PLAN | PULL  |
| PUSH   | ROLL  | SAFE | SMOKE |
| STOP   |       |      |       |





# PICTURE IT

# PICTURE IT

OUTCOMES	TEACHING STRATEGY	RESOURCES
Tell a story from a series of pictures.	Observe a series of pictures from an event, eg. bush fire and relate a narrative to accompany the pictures.	
Use pictures, sound and language to tell a story.	Make a book from a story written by the class. Act out the story/tell the story	
Investigate how pictures give us information.	Use pictures of stop, drop and roll and "keep low" to practise a task.	

# TOY WORLD

# TOY WORLD

OUTCOMES	TEACHING STRATEGY	RESOURCES
<p>Investigate how toys and games can be made to move.</p>	<p>1) List various ways in which toys can be made to move</p> <ul style="list-style-type: none"> <li>• pulling a string</li> <li>• winding a spring</li> <li>• pushing and pulling</li> <li>• motors, gears and pulleys and levers.</li> </ul> <p>2) “Show and tell” a favourite toy which moves.</p>	
<p>Design and make a toy or plaything that moves.</p>	<p>1) Design a mask so that the ears will move.</p> <p>2) Construct a cut out model of a fire tanker so that the wheels will turn.</p> <p>3) Construct a cardboard puppet rural firefighter.</p>	
<p>Compare olden day toys with modern toys.</p>	<p>1) Collect and/or observe pictures of “old” toys and compare them with their modern counterparts.</p> <p>2) Compare toys from different cultures.</p>	

# CARDBOARD PUPPET RURAL FIREFIGHTER

## Materials:

- paper fasteners
- cotton or wool
- pencils
- rubber bands
- cardboard
- coloured pencils

1. Colour in the puppet parts.

O = orange    Y = yellow    B = blue    B = black

2. Cut out the puppet parts.

3. Connect the limbs to the body using paper fasteners.

4. Join two sticks or pencils as shown in the diagram to form a cross.

5. Pierce holes in the hands and feet of the puppet.

6. Tie a piece of string or wool from the hands and feet to the ends of the pencil.

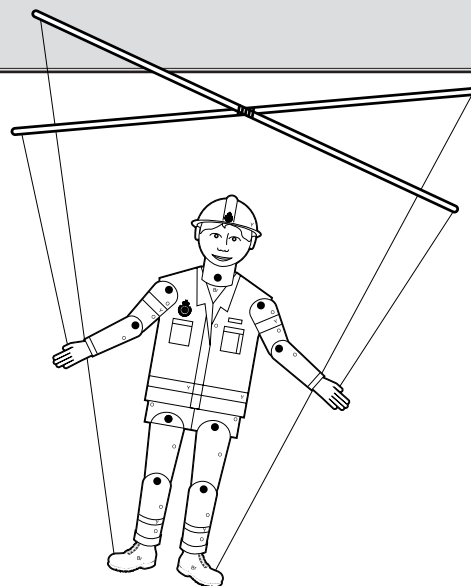

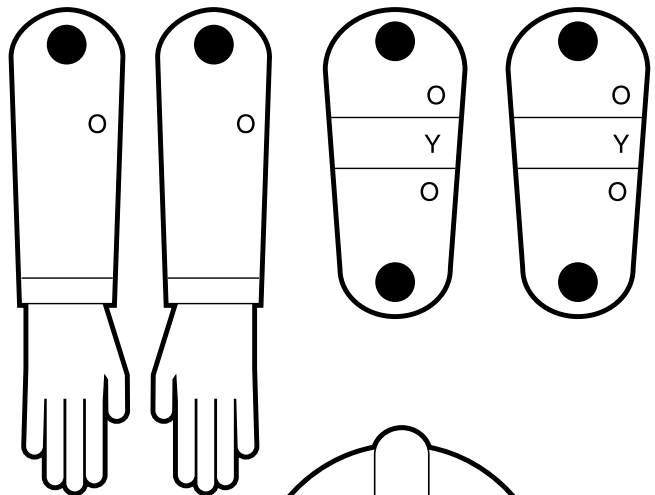
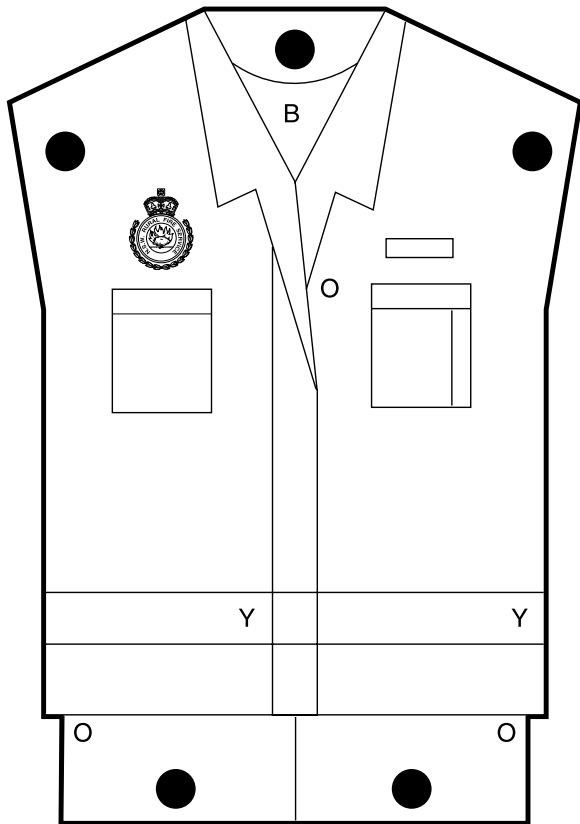
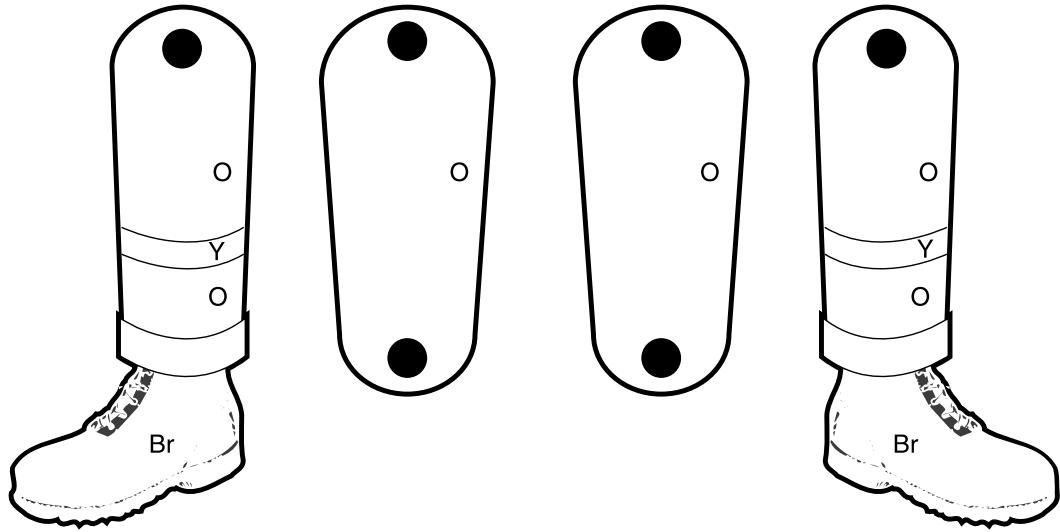

# WHAT'S FOR LUNCH?

# WHAT'S FOR LUNCH?

OUTCOMES	TEACHING STRATEGY	RESOURCES
<p>Recognise healthy foods and where they come from.</p>	<ol style="list-style-type: none"> <li>1) Using pictures, classify a collection of food into healthy food and not so healthy food.</li> <li>2) Design and make a healthy lunch.</li> <li>3) Create an attractive menu.</li> <li>4) Investigate the need for healthy food.</li> <li>5) Survey members of the class to find out what is the most popular lunch.</li> <li>6) Trace the origins of a variety of foods.</li> <li>7) Understand what happens to bodies if healthy food is not eaten.</li> </ol>	
<p>Recognise different diets needed by different groups of people.</p>	<ol style="list-style-type: none"> <li>1) Discuss the types of food eaten in hospital.</li> <li>2) Discuss the type of food which would be eaten by an active firefighter.</li> <li>3) Recognise the need to drink plenty of water when it is very hot.</li> </ol>	